

ATC 700 B Series NPO Porcelain and Ceramic Multilayer Capacitors

- Case B Size (.110" x .110")
- Low ESR/ESL
- Low Noise
- Rugged Construction
- Available with Encapsulation Option*
- Capacitance Range 0.1 pF to 5100 pF
- Zero TCC
- High Self-Resonance
- Established Reliability (QPL)
- Extended WVDC up to 1500 VDC

ATC, the industry leader, is announcing new improved ESR/ESL performance for the 700 B Series RF/Microwave Capacitors. The superior high self-resonance and zero TCC characteristic of this Series provide excellent performance over a broad range of RF and microwave applications requiring minimum drift, including RF power. Porcelain and ceramic construction provide a rugged, hermetic package.

ATC offers an encapsulation option for applications requiring extended protection against arc-over and corona.

Typical functional applications: Bypass, Coupling, Tuning and DC Blocking.

Typical circuit applications: Filters, Oscillators, Timing and RF Power Amplifiers.

*For leaded styles only.

ENVIRONMENTAL TESTS

ATC 700 B Series Capacitors are designed and manufactured to meet and exceed the requirements of EIA-198, MIL-PRF-55681 and MIL-PRF-123.

THERMAL SHOCK:

MIL-STD-202, Method 107, Condition A.

MOISTURE RESISTANCE:

MIL-STD-202, Method 106.

LOW VOLTAGE HUMIDITY:

MIL-STD-202, Method 103, Condition A, with 1.5 Volts DC applied while subjected to an environment of 85°C with 85% relative humidity for 240 hours min.

LIFE TEST:

MIL-STD-202, Method 108, for 2000 hours, at 125°C.

200% WVDC applied.

Voltage Applied:

200% of WVDC for capacitors rated at 500 volts DC or less.

120% of WVDC for capacitors rated at 1250 volts DC or less.

100% of WVDC for capacitors rated above 1250 volts DC.

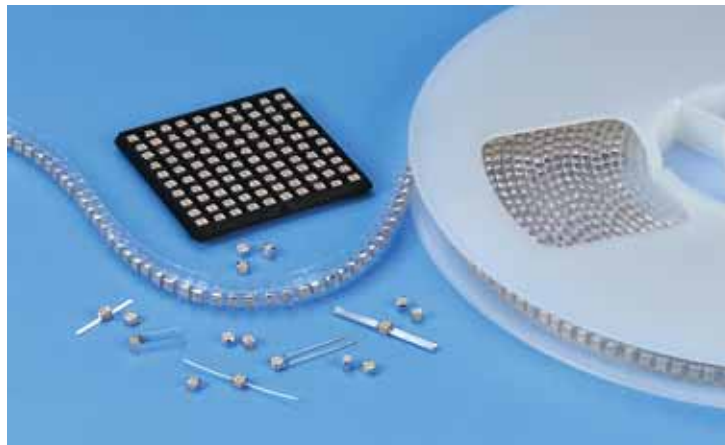

ELECTRICAL AND MECHANICAL SPECIFICATIONS

QUALITY FACTOR (Q):

Greater than 10,000 (0.1 pF to 200 pF) @ 1 MHz.

Greater than 2000 (220 pF to 1000 pF) @ 1 MHz.

Greater than 2000 (1100 pF to 5100 pF) @ 1 KHz.

TEMPERATURE COEFFICIENT OF CAPACITANCE (TCC):

0 ±30 PPM/°C (-55°C to +125°C)

INSULATION RESISTANCE (IR):

0.1 pF to 470 pF:

10⁶ Megohms min. @ +25°C at rated WVDC.

10⁵ Megohms min. @ +125°C at rated WVDC.

510 pF to 5100 pF:

10⁵ Megohms min. @ +25°C at rated WVDC.

10⁴ Megohms min. @ +125°C at rated WVDC.

WORKING VOLTAGE (WVDC): See Capacitance Values Table, page 2.

DIELECTRIC WITHSTANDING VOLTAGE (DWV):

250% of WVDC for capacitors rated at 500 volts DC or less for 5 seconds.

150% of WVDC for capacitors rated at 1250 volts DC or less for 5 seconds.

120% of WVDC for capacitors rated above 1250 volts DC for 5 seconds.

RETRACE: Less than ±(0.02% or 0.02 pF), whichever is greater.

AGING EFFECTS: None

PIEZOELECTRIC EFFECTS: None

(No capacitance variation with voltage or pressure).

CAPACITANCE DRIFT: ±(0.02% or 0.02 pF), whichever is greater.

OPERATING TEMPERATURE RANGE:

0.1 to 5100 pF: from -55°C to +125°C (No derating of working voltage)

TERMINATION STYLES:

Available in various surface mount and leaded styles.

See Mechanical Configurations, page 3.

TERMINAL STRENGTH: Terminations for chips and pellets withstand a pull of 5 lbs. min., 15 lbs. typical, for 5 seconds in direction perpendicular to the termination surface of the capacitor. Test per MIL-STD-202, method 211.

ATC # 001-814 Rev. O 3/10



AMERICAN

ATC North America
+1-631-622-4700
sales@atceramics.com

TECHNICAL

ATC Europe
+46 8 6800410
sales@atceramics-europe.com

CERAMICS

ATC Asia
+86-755-2386-8759
sales@atceramics-asia.com



www.atceramics.com

ATC 700 B Capacitance Values

CAP. CODE	CAP. (pF)	TOL.	RATED WVDC		CAP. CODE	CAP. (pF)	TOL.	RATED WVDC		CAP. CODE	CAP. (pF)	TOL.	RATED WVDC		CAP. CODE	CAP. (pF)	TOL.	RATED WVDC					
			STD.	EXT.				STD.	EXT.				STD.	EXT.				STD.	EXT.				
0R1	0.1	B	500	1500	3R3	3.3	B, C, D	500	1500	330	33	F, G, J K, M	500	1500	331	330	F, G, J K, M	500	1500				
0R2	0.2				3R6	3.6				360	36				331	360							
0R3	0.3	B, C			EXTENDED VOLTAGE	3R9				3.9	1500				EXT VOLT	390				39	391	390	200
0R4	0.4					4R3				4.3						430				43	431	430	
0R5	0.5	B, C, D			EXTENDED VOLTAGE	4R7				4.7	500				EXTENDED VOLTAGE	470				47	471	470	100
0R6	0.6					5R1				5.1						510				51	511	510	
0R7	0.7					5R6				5.6						560				56	561	560	
0R8	0.8					6R2				6.2						620				62	621	620	
0R9	0.9					6R8				6.8						680				68	681	680	
1R0	1.0					7R5				7.5						750				75	751	750	
1R1	1.1		8R2	8.2		820	82	821	820														
1R2	1.2		9R1	9.1		910	91	911	910														
1R3	1.3		B, C, D	EXTENDED VOLTAGE		100	10	1000	EXTENDED VOLTAGE	101		100	102	1000		50							
1R4	1.4					110	11			111		110	112	1100									
1R5	1.5	120			12	121	120			122	1200												
1R6	1.6	130			13	131	130			152	1500												
1R7	1.7	150			15	151	150			182	1800												
1R8	1.8	160			16	161	160			222	2200												
1R9	1.9	180			18	181	180			272	2700												
2R0	2.0	200			20	201	200			302	3000												
2R1	2.1	220			22	221	220			332	3300												
2R2	2.2	240			24	241	240			392	3900												
2R4	2.4	270	27	271	270	472	4700																
2R7	2.7	300	30	301	300	512	5100																
3R0	3.0																						

VRMS = 0.707 x WVDC

• SPECIAL VALUES, TOLERANCES, HIGHER WVDC AND MATCHING AVAILABLE. • ENCAPSULATION OPTION AVAILABLE. PLEASE CONSULT FACTORY.

Capacitance values in **bold** type indicate porcelain dielectric. All other capacitance values indicate ceramic dielectric.

All 700 B Capacitors are available laser marked with ATC's identification, capacitance code and tolerance.

NOTE: EXTENDED WVDC DOES NOT APPLY TO CDR PRODUCTS.

ATC PART NUMBER CODE

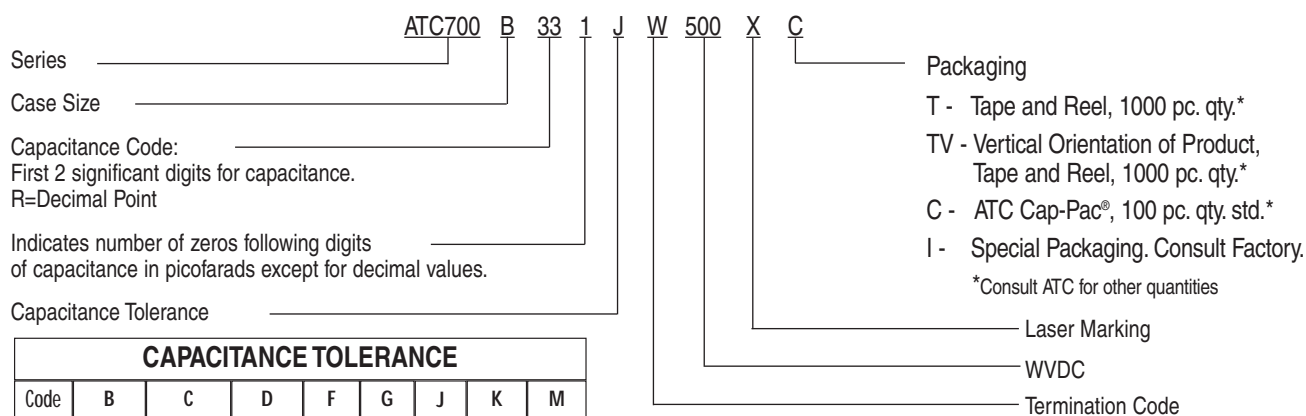

The above part number refers to a 700 B Series (case size B) 330 pF capacitor, J tolerance (±5%), 500 WVDC, with W termination (Tin/Lead, Solder Plated over Nickel Barrier), laser marking and ATC Cap-Pac® packaging.

ATC accepts orders for our parts using designations **with** or **without** the "ATC" prefix. Both methods of defining the part number are equivalent, i.e., part numbers referenced with the "ATC" prefix are interchangeable to parts referenced without the "ATC" prefix. Customers are free to use either in specifying or procuring parts from American Technical Ceramics.

For additional information and catalogs contact your ATC representative or call direct at (+1-631) 622-4700. Consult factory for additional performance data.

A M E R I C A N T E C H N I C A L C E R A M I C S

ATC North America

ATC Europe

ATC Asia

+1-631-622-4700 • sales@atceramics.com

+46 8 6800410 • sales@atceramics-europe.com

+86-755-2396-8759 • sales@atceramics-asia.com

w w w . a t c e r a m i c s . c o m

ATC 700 B Capacitors: Mechanical Configurations

ATC SERIES & CASE SIZE	ATC TERM. CODE	MIL-PRF-55681	CASE SIZE & TYPE	OUTLINES W/T IS A TERMINATION SURFACE	BODY DIMENSIONS INCHES (mm)			LEAD AND TERMINATION DIMENSIONS AND MATERIALS			
					LENGTH (L)	WIDTH (W)	THICKNESS (T)	OVERLAP (Y)	MATERIALS		
700B	W	CDR14BP	B Solder Plate		.110 +.020 -.010 (2.79 +0.51 -0.25)	.110 ±.015 (2.79 ±0.38)	.102 (2.59) max.	.015 (0.38) ±.010 (0.25)	Tin/Lead, Solder Plated over Nickel Barrier Termination		
700B	P	CDR14BP	B Pellet		.110 +.035 -.010 (2.79 +0.89 -0.25)	.110 ±.015 (2.79 ±0.38)			Heavy Tin/Lead Coated, over Nickel Barrier Termination		
700B	T	N/A	B Solderable Nickel Barrier		.110 +.020 -.010 (2.79 +0.51 -0.25)	.110 ±.015 (2.79 ±0.38)			RoHS Compliant Tin Plated over Nickel Barrier Termination		
700B	CA	CDR13BP	B Gold Chip		.110 +.020 -.010 (2.79 +0.51 -0.25)	.110 ±.015 (2.79 ±0.38)			RoHS Compliant Gold Plated over Nickel Barrier Termination		
700B	MS	CDR21BP	B Microstrip		.135 ±.015 (3.43 ±0.38)	.110 ±.015 (2.79 ±0.38)	.120 (3.05) max.	N/A	Length (L _L)	Width (W _L)	Thickness (T _L)
700B	AR	CDR22BP	B Axial Ribbon						.250 (6.35) min.	.093 ±.005 (2.36 ±0.13)	.004 ±.001 (.102 ±.025)
700B	RR	CDR24BP	B Radial Ribbon						.145 ±.020 (3.68 ±0.51)	.102 (2.59) max.	N/A
700B	RW	CDR23BP	B Radial Wire								
700B	AW	CDR25BP	B Axial Wire								

Additional lead styles available: Narrow Microstrip (NM), Narrow Axial Ribbon (NA) and Vertical Narrow Microstrip (H). Other lead lengths are available; consult factory. All leads are high purity silver attached with high temperature solder and are **RoHS** compliant. For a complete military catalog, request American Technical Ceramics document ATC 001-818.

AMERICAN TECHNICAL CERAMICS

ATC North America
+1-631-622-4700 • sales@atceramics.com

ATC Europe
+46 8 6800410 • sales@atceramics-europe.com

ATC Asia
+86-755-2396-8759 • sales@atceramics-asia.com

w w w . a t c e r a m i c s . c o m

ATC 700 B Capacitors: Non-Magnetic Mechanical Configurations*

ATC SERIES & CASE SIZE	ATC TERM. CODE	MIL-PRF-55681	CASE SIZE & TYPE	OUTLINES W/T IS A TERMINATION SURFACE	BODY DIMENSIONS INCHES (mm)			LEAD AND TERMINATION DIMENSIONS AND MATERIALS			
					LENGTH (L)	WIDTH (W)	THICKNESS (T)	OVERLAP (Y)	MATERIALS		
700B	WN	Meets Requirements	B Non-Mag Solder Plate		.110 +.025 -.010 (2.79 +0.64 -0.25)	.110 ±.015 (2.79 ±0.38)	.102 (2.59) max.	.015 (0.38) ±.010 (0.25)	Tin/Lead, Solder Plated over Non-Magnetic Barrier Termination		
700B	PN	Meets Requirements	B Non-Mag Pellet		.110 +.035 -.010 (2.79 +0.89 -0.25)	.110 ±.015 (2.79 ±0.38)			Heavy Tin/Lead Coated, over Non-Magnetic Barrier Termination		
700B	TN	Meets Requirements	B Non-Mag Solderable Barrier		.110 +.025 -.010 (2.79 +0.64 -0.25)	.110 ±.015 (2.79 ±0.38)			RoHS Compliant Tin Plated over Non-Magnetic Barrier Termination		
700B	MN	Meets Requirements	B Non-Mag Microstrip		.135 ±.015 (3.43 ±0.38)	.110 ±.015 (2.79 ±0.38)	.120 (3.05) max.	N/A	Length (L _L)	Width (W _L)	Thickness (T _L)
700B	AN	Meets Requirements	B Non-Mag Axial Ribbon						.250 (6.35) min.	.093 ±.005 (2.36 ±0.13)	.004 ±.001 (.102 ±.025)
700B	FN	Meets Requirements	B Non-Mag Radial Ribbon						.145 ±.020 (3.68 ±0.51)	.106 (2.69) max.	.500 (12.7) min.
700B	RN	Meets Requirements	B Non-Mag Radial Wire								
700B	BN	Meets Requirements	B Non-Mag Axial Wire								

*Capacitors with values greater than 200 pF contain a trace magnetic element that may exhibit weak magnetic properties.

Additional lead styles available: Narrow Microstrip (DN), Narrow Axial Ribbon (GN) and Vertical Narrow Microstrip (HN). Other lead lengths are available; consult factory; All leads are high purity silver attached with high temperature solder and are **RoHS compliant.

Suggested Mounting Pad Dimensions

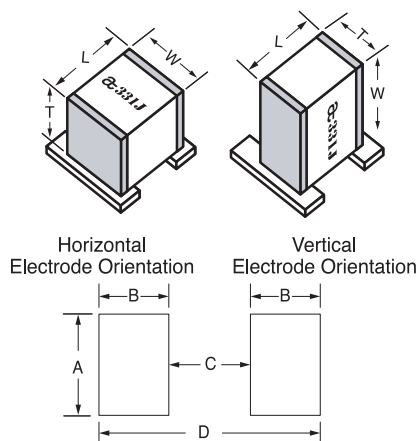

Case B Vertical Mount

Cap Value		A Min.	B Min.	C Min.	D Min.
0.1 pF	Normal	.065	.050	.075	.175
	High Density	.045	.030	.075	.135
0.2 pF	Normal	.090	.050	.075	.175
	High Density	.070	.030	.075	.135
0.3 to 510 pF	Normal	.110	.050	.075	.175
	High Density	.090	.030	.075	.135
> 510 pF	Normal	.120	.050	.075	.175
	High Density	.100	.030	.075	.135

Horizontal Mount

All values		A Min.	B Min.	C Min.	D Min.
	Normal	.130	.050	.075	.175
High Density	.110	.030	.075	.135	

A M E R I C A N T E C H N I C A L C E R A M I C S

ATC North America

+1-631-622-4700 • sales@atceramics.com

ATC Europe

+46 8 6800410 • sales@atceramics-europe.com

ATC Asia

+86-755-2396-8759 • sales@atceramics-asia.com

w w w . a t c e r a m i c s . c o m

ATC 700 B Performance Data

**ESR VS. CAPACITANCE
ATC SERIES 700, CASE B**

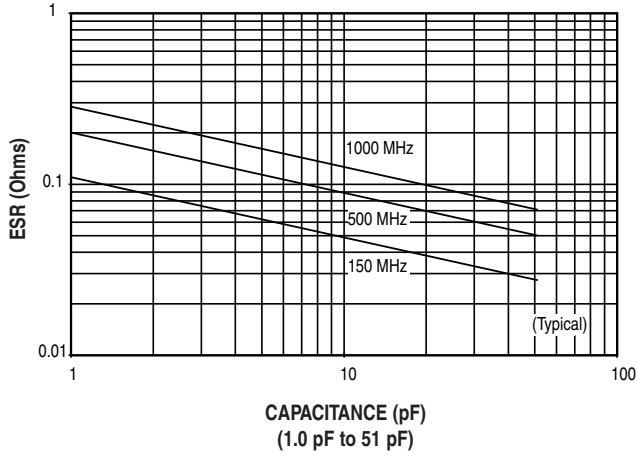

**Q VS. CAPACITANCE
ATC SERIES 700, CASE B**

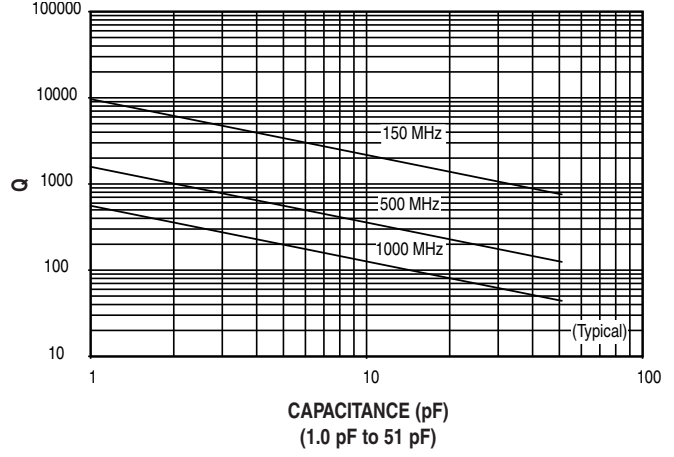

**ESR VS. CAPACITANCE
ATC SERIES 700, CASE B**

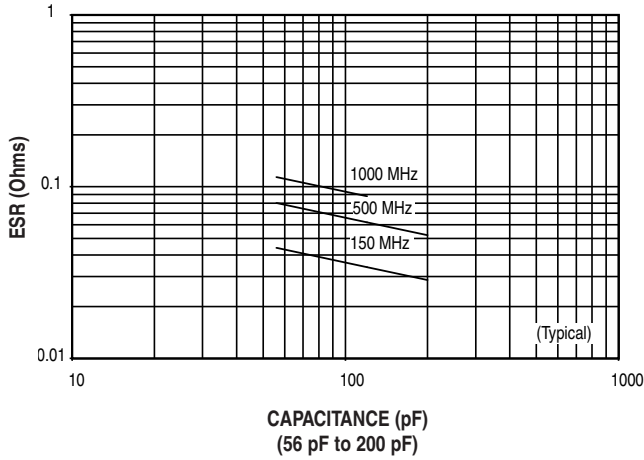

**Q VS. CAPACITANCE
ATC SERIES 700, CASE B**

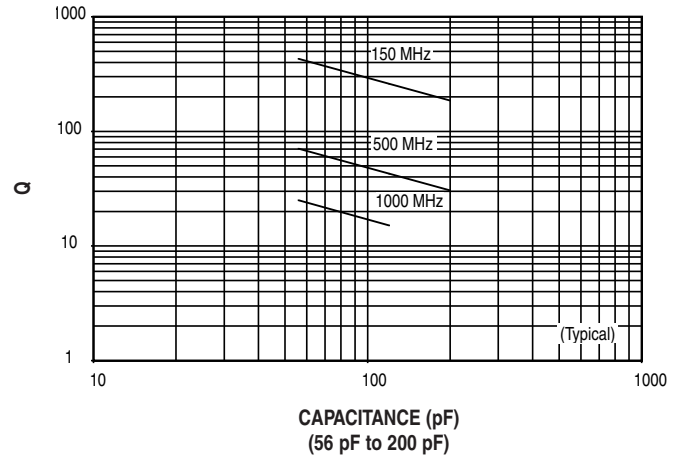

**ESR VS. CAPACITANCE
ATC SERIES 700, CASE B**

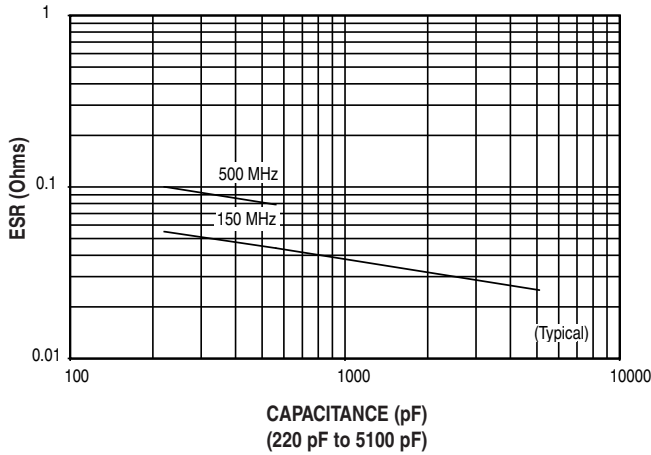

**Q VS. CAPACITANCE
ATC SERIES 700, CASE B**

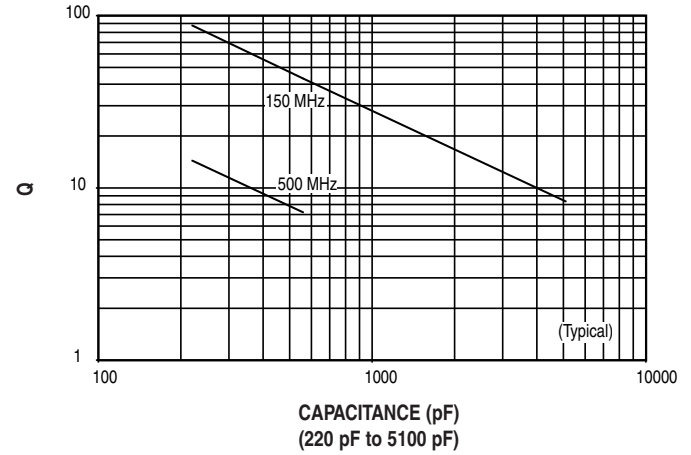

A M E R I C A N T E C H N I C A L C E R A M I C S

ATC North America
+1-631-622-4700 • sales@atceramics.com

ATC Europe
+46 8 6800410 • sales@atceramics-europe.com

ATC Asia
+86-755-2396-8759 • sales@atceramics-asia.com

w w w . a t c e r a m i c s . c o m

ATC 700 B Performance Data

**SERIES RESONANCE VS. CAPACITANCE
ATC SERIES 700, CASE B**

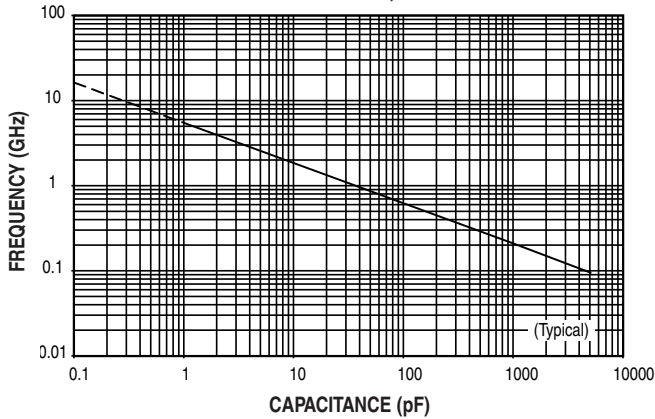

**CURRENT RATING VS. CAPACITANCE
ATC SERIES 700, CASE B**

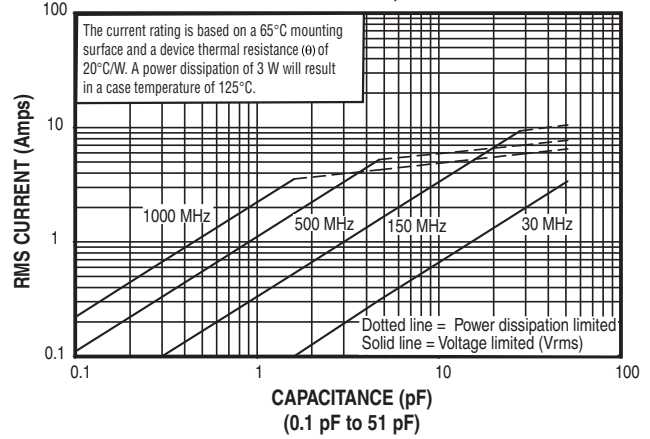

**CURRENT RATING VS. CAPACITANCE
ATC SERIES 700, CASE B**

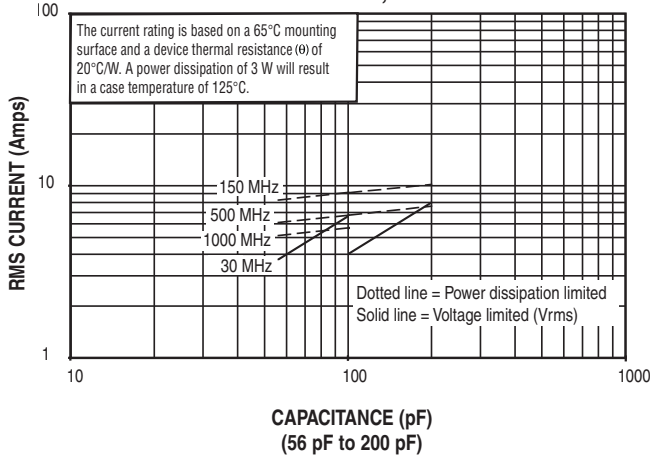

**CURRENT RATING VS. CAPACITANCE
ATC SERIES 700, CASE B**

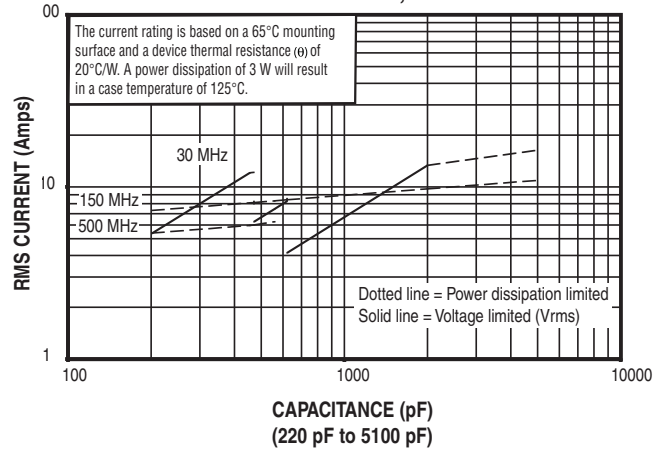

**CAPACITANCE CHANGE VS. TEMPERATURE
ATC SERIES 700, CASE B**

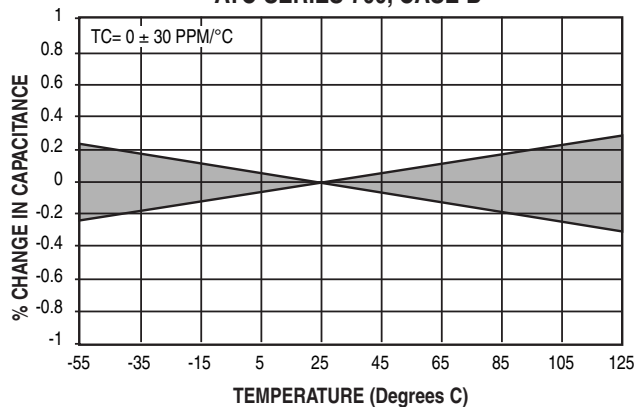

A M E R I C A N T E C H N I C A L C E R A M I C S

ATC North America

+1-631-622-4700 • sales@atceramics.com

ATC Europe

+46 8 6800410 • sales@atceramics-europe.com

ATC Asia

+86-755-2396-8759 • sales@atceramics-asia.com

w w w . a t c e r a m i c s . c o m

ATC 700 B Performance Data

CURRENT RATING VS. CAPACITANCE
ATC SERIES 700, CASE B, EXTENDED VOLTAGE

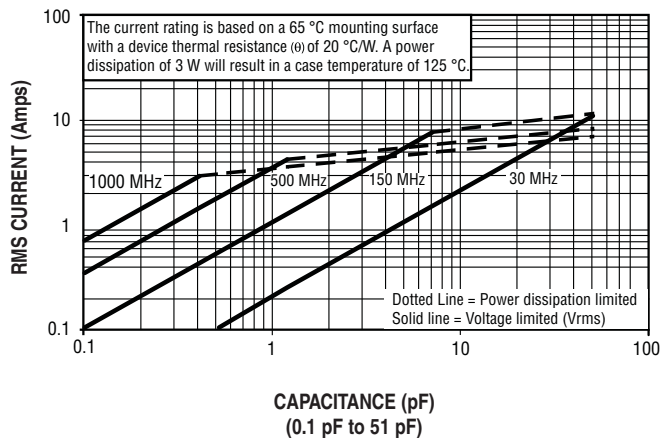

CURRENT RATING VS. CAPACITANCE
ATC SERIES 700, CASE B, EXTENDED VOLTAGE

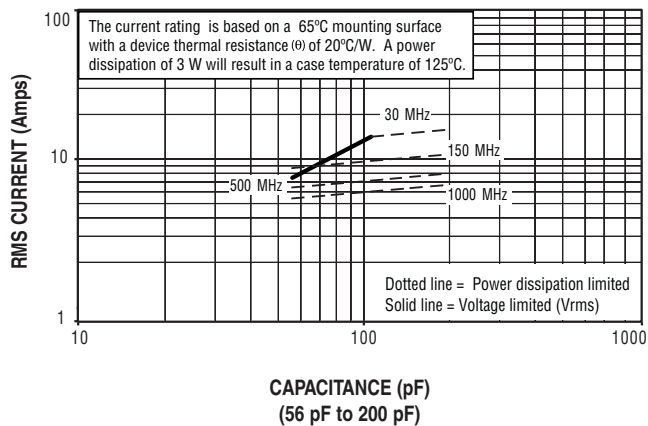

A M E R I C A N T E C H N I C A L C E R A M I C S

ATC North America
 +1-631-622-4700 • sales@atceramics.com

ATC Europe
 +46 8 6800410 • sales@atceramics-europe.com

ATC Asia
 +86-755-2396-8759 • sales@atceramics-asia.com

w w w . a t c e r a m i c s . c o m

Sales of ATC products are subject to the terms and conditions contained in American Technical Ceramics Corp. Terms and Conditions of Sale (ATC document #001-992 Rev. B 12/05). Copies of these terms and conditions will be provided upon request. They may also be viewed on ATC's website at www.atceramics.com/productfinder/default.asp. Click on the link for Terms and Conditions of Sale.

ATC has made every effort to have this information as accurate as possible. However, no responsibility is assumed by ATC for its use, nor for any infringements of rights of third parties which may result from its use. ATC reserves the right to revise the content or modify its product without prior notice.

© 1996 American Technical Ceramics Corp. All Rights Reserved

ATC # 001-814 Rev. O 3/10

A M E R I C A N T E C H N I C A L C E R A M I C S

ATC North America

ATC Europe

ATC Asia

+1-631-622-4700 • sales@atceramics.com

+46 8 6800410 • sales@atceramics-europe.com

+86-755-2396-8759 • sales@atceramics-asia.com

w w w . a t c e r a m i c s . c o m